

Features

- Multi-channel WDRC processing
- Four independently configurable Biquad Filters
- Fully adjustable crossover frequencies
- Embedded FRONTWAVE® technology *
- AGC Detector in each channel with adjustable time constants (Single or Twin Detector)
- Flexible WDRC I/O curve adjustment (channel independent)
- Wideband gain adjustment with external VC option
- Notch filter (variable centre and width) and dynamic depth (gain dependent)
- Soft squelch (low level expansion) with variable threshold and variable time constants
- Telecoil option
- AGCo (variable threshold and time constants)
- Digital peak clipping option
- Low battery indicator
- Tone generator (programmable level and frequency)
- Four memories with full configuration storage
- Momentary and static memory select operation
- Separate static memory D select switch*
- Audible memory change indicator

* This option is available on specific products.

Description

The S03 Product Abstraction Layer™ (PAL) in combination with second generation PARAGON™ DIGITAL hybrids (GB3211, GB3215, GA3214) provides an advanced, four-channel Wide Dynamic Range Compression (WDRC) DSP system with embedded FRONTWAVE capability. The new features added in S03 PAL revision include software configurable, two memory select switches, and audible memory change indicator tones.

The highly configurable digital signal processor enables extremely versatile fitting with independent channel compression characteristics, including five parameter I/O curve adjustment and variable AGC time constants. All programmable parameters, including the crossover frequencies, have generous adjustment ranges and excellent resolution. Each channel contains independent AGC control with Sound Design Technologies' proven *Twin Detector* approach.

FRONTWAVE enables the efficient addition of multi-microphone directionality with exceptional flexibility. A wide range of polar patterns are possible and can be programmed in the field after a simple calibration procedure is performed on the complete hearing aid by the manufacturer. Different polar patterns can be programmed and can be changed as required within each memory.

Advanced features include low-level expansion (squelch), a fully programmable notch filter with optional gain dependent operation, and a pure tone generator enabling in situ audiometry.

This data sheet is part of a documentation set available for this product. For a list of other documents, refer to the [Getting Started with PARAGON™ DIGITAL](#) information note.

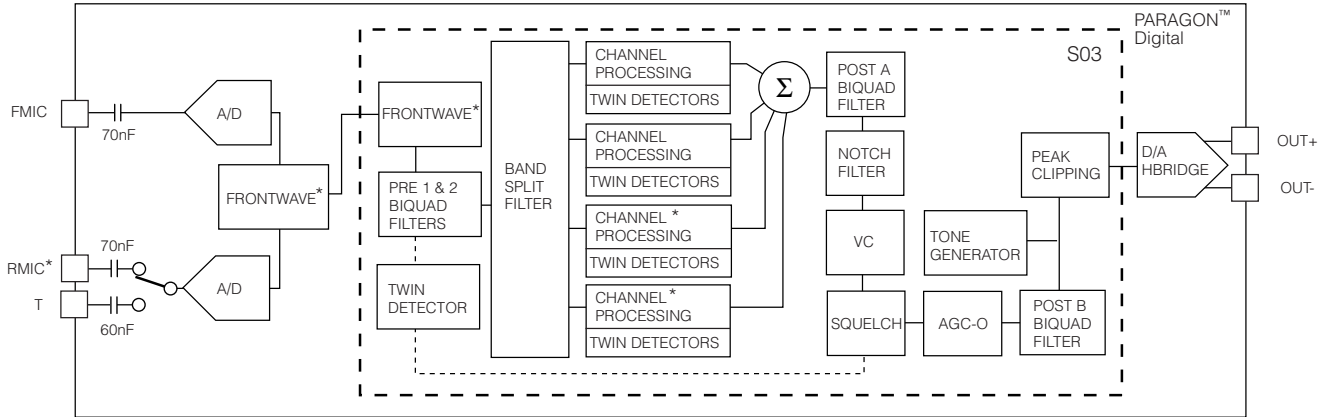

1. Block Diagram



* This option is available on specific products.

Figure 1: Block Diagram

2. Warnings

<p>CAUTION ELECTROSTATIC SENSITIVE DEVICES DO NOT OPEN PACKAGES OR HANDLE EXCEPT AT A STATIC-FREE WORKSTATION</p>	
<p>CAUTION MOISTURE SENSITIVE DEVICES NON-RoHS COMPLIANT — LEVEL 3 MSL RoHS COMPLIANT — LEVEL 4 MSL DO NOT OPEN PACKAGES EXCEPT UNDER CONTROLLED CONDITIONS</p>	

3. Electrical Characteristics

Table 1: Electrical Characteristics

Parameter	Range		Units	Resolution	Accuracy
	Min	Max			
FRONTWAVE® 1					
Time Delay	0	40	µs	1	Type 1
Low Frequency Boost	20		dB	N/A	N/A
Low Frequency Equalizer Corner Frequency	0.05	16	kHz	Table 1	Type 1,2
Telecoil					
Mic attenuation in MT mode	0	-18	dB	N/A	N/A
Low Pass compensation Filter	500		Hz	N/A	Type 1
Filter Banks					
Crossover Frequency (Ch1/2)	0.300	7.6	kHz	N/A	Type 1,2
Crossover Frequency (Ch2/3) ¹	0.500	7.8	kHz	N/A	Type 1,2
Crossover Frequency (Ch3/4) ¹	0.700	8	kHz	N/A	Type 1,2
Frequency Shaping					
Pre I and Pre 2 Biquad Filter	Design Specific			N/A	Type 1,2
Post A and Post B Biquad Filter	Design Specific			N/A	Type 1,2
Independent Channel Processing					
Low Level Gain	-18	42	dB	Table 2	Type 3
High Level Gain	-18	42	dB	Table 2	Type 3
Lower Threshold	30	110	dB SPL	Table 2	Type 3
Upper Threshold	30	110	dB SPL	Table 2	Type 3
Compression Ratio	1:1	100:1	Ratio	Table 1	Type 3
AGC Attack Time Constant (Fast & Slow)	0.25	8192	ms	Table 1	Type 1,3
AGC Release Time Constant (Fast & Slow)	0.25	8192	ms	Table 1	Type 1,3
Wideband System Gain					
Wideband System Gain	-36	12	dB	Table 2	Type 3

Table 1: Electrical Characteristics (Continued)

Parameter	Range		Units	Resolution	Accuracy
	Min	Max			
Wideband Attack Time Constant (Fast & Slow)	0.25	8192	ms	Table 2	Type 1,3
Wideband Release Time Constant (Fast & Slow)	0.25	8192	ms	Table 2	Type 1,3
Converter Gain	See hardware Data Sheet.				
External VC	-48	0	dB	Table 3	Type 3
Internal VC Attenuator	-48	0	dB	Table 3	Type 3
Total System Gain					
Total System Gain	-19	83	dB	N/A	Note 1
AGCo					
AGCo Output Limiting	-40	0	dBFS*	Table 3	Type 3
AGCo Compression Ratio	$\infty : 1$		Ratio	N/A	N/A
AGCo Attack Time Constant (Fast & Slow)	0.25	8192	ms	Table 2	Type 1,3
AGCo Release Time Constant (Fast & Slow)	0.25	8192	ms	Table 2	Type 1,3
* Peak output is defined as largest sine wave possible at a the resonant frequency of the receiver.					
¹ This option is available on specific products.					
Peak Clipper					
PC Output Limiting	-40	0	dB	Table 3	Type 3
Low Level Expansion (Soft Squelch)					
Squelch Expansion Ratio	1:2		ratio	N/A	N/A
Squelch Threshold	30	60	dB SPL	Table 3	Type 3
Squelch Attack Time	Same as Wideband Fast Attack Time Constant				
Squelch Release Time	Same as Wideband Fast Release Time Constant				
Notch Filter					
NF Center Frequency	0.8	5	kHz	N/A	Type 1,2
NF Attenuation	0	12	dB	Table 2	N/A
NF Bandwidth	1/12	1	octave	Table 2	N/A

Table 1: Electrical Characteristics (Continued)

Parameter	Range		Units	Resolution	Accuracy
	Min	Max			
Tone Generator					
Pure Tone Frequency	0.25	16	kHz	Table 2	Type 1,2
Pure Tone Amplitude	-96	0	dBFS	Table 3	Type 3

Notes:

- Total System Gain consists of *Wideband System Gain + High and Low Independent Channel Gains + Converter Gain* and accuracy of this parameter is dependent on accuracy of the components.
Accuracy definitions:
Type 1: accuracy is determined by the clock frequency deviation.
Type 2: accuracy is determined by the quantization error of 16bit coefficient and 20bit or higher data word.
Type 3: accuracy is determined by the quantization error of a parameter word (see table 2 for word length) and 20bit or higher data word.
- For parameter description, refer to PARAGON™ DIGITAL Reference Guide (Document #20143).

Table 2: Parameter Values Supported by GB3210-S02 PAL

Compression Ratio	1; 1.016; 1.032; 1.050; 1.067; 1.085; 1.103; 1.123; 1.143; 1.164; 1.185; 1.210; 1.230; 1.255; 1.28; 1.31; 1.33; 1.36; 1.39; 1.42; 1.45; 1.49; 1.52; 1.56; 1.60; 1.64; 1.68; 1.73; 1.78; 1.83; 1.88; 1.94; 2.00; 2.06; 2.13; 2.21; 2.29; 2.37; 2.46; 2.56; 2.67; 2.78; 2.90; 3.05; 3.20; 3.37; 3.56; 3.76; 4.00; 4.27; 4.57; 4.92; 5.33; 5.82; 6.40; 7.11; 8.00; 9.14; 10.67; 12.80; 16.00; 21.33; 32.00; 64.00; 100	Ratio
Attack and Release Time Constant	0.25; 0.5; 1; 2; 4; 8; 16; 32; 64; 128; 256; 512; 1024; 2048; 4096; 8192	ms
NF Attenuation	0; 6; 12	dB
NF Bandwidth	1/12; 1/6; 1/4; 1/3; 1/2; 1	Octave
Pure Tone Frequency*	0.250; 0.500; 0.640; 0.800; 1.00; 1.28; 1.60; 2.00; 3.20; 4.00; 6.40; 8.00; 16.00	kHz

Notes: * Other frequencies are available with increased harmonics components.

Table 3: Resolution of the Parameters

The resolution of the parameters listed in this table is determined by bit quantization:
 $D = 20\log(n) - 20\log(n-1)$; where n = decimal representation of binary word.

Parameter	Parameter Word Length	Resolution for Lowest Gain / Level	Resolution for Highest Gain / Level
Low Level Gain	20bits	0.01682 dB	0.00002 dB
High Level Gain	20bits	0.01682 dB	0.00002 dB
Lower Threshold	20bits	1.58362 dB	0.00002 dB
Upper Threshold	20bits	1.58362 dB	0.00002 dB
Wideband System Gain	11bits	6.02060 dB	0.03426 dB
Internal VC Attenuator	9bits	3.52183 dB	0.01701 dB
External VC	9bits	3.52183 dB	0.01701 dB
AGCo Output Limiting	20bits	0.00166 dB	0.00002 dB
PC Output Limiting	20bits	0.00166 dB	0.00002 dB
Squelch Threshold	20bits	1.58362 dB	0.05280 dB
Pure Tone Amplitude	16bits	6.02060 dB	0.00027 dB
Compression Ratio	7bits	N/A	N/A
Attack and Release Time constants	5bits	N/A	N/A

Note: Parameter Word Length includes the sign bit, where applicable.

Table 4: Memory Select Switches State Table

MSS	Control bit		Mechanical switch		Action
	D_only	P3_en	MS2	MS1	
Momentary mode					
0	X	X	X	LO/Z	No action
0	X	X	X	HI	Next Mem
Static mode					
1	0	0	LO	LO	Mem C
1	0	0	LO	Z	Mem C
1	0	0	LO	HI	Mem D
1	0	0	HI	LO	Mem A
1	0	0	HI	Z	Mem A
1	0	0	HI	HI	Mem B
1	0	1	LO	LO	Mem B
1	0	1	LO	Z	Mem C
1	0	1	LO	HI	Mem D
1	0	1	HI	LO	Mem C
1	0	1	HI	Z	Mem A
1	0	1	HI	HI	Mem B
1	1	0	LO	LO	Mem D
1	1	0	LO	Z	Mem D
1	1	0	LO	HI	Mem D
1	1	0	HI	LO	Mem A
1	1	0	HI	Z	Mem A
1	1	0	HI	HI	Mem B
1	1	1	LO	LO	Mem D
1	1	1	LO	Z	Mem D
1	1	1	LO	HI	Mem D
1	1	1	HI	LO	Mem C
1	1	1	HI	Z	Mem A
1	1	1	HI	HI	Mem B

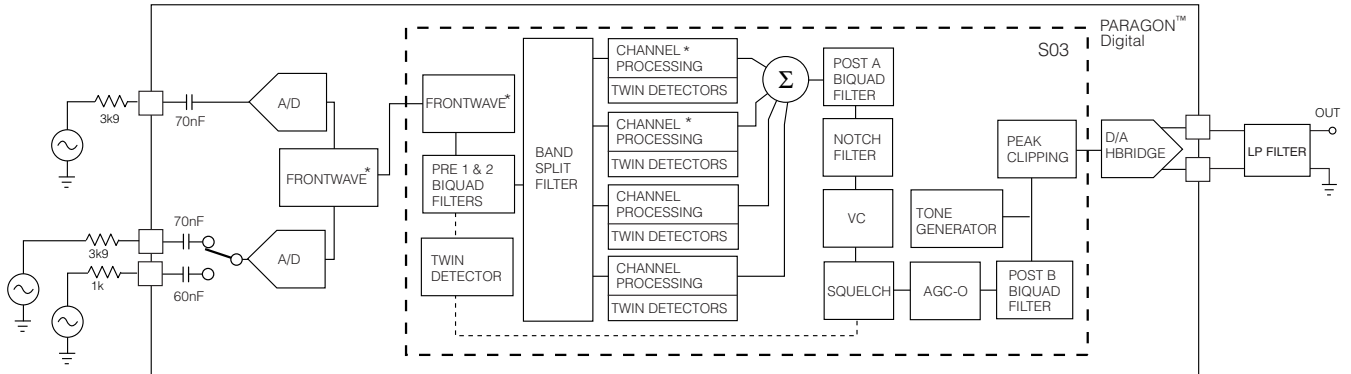

*This option is available on specific products.

Figure 2: Characterization Circuit

4. Revision History

Version	ECR	Date	Change Description
1	148170	October 2007	Document conversion to new template.

DOCUMENT IDENTIFICATION**DATA SHEET**

The product is in production. Sound Design Technologies reserves the right to make changes to the product at any time without notice to improve reliability, function or design, in order to provide the best product possible.

SOUND DESIGN TECHNOLOGIES

Mailing Address: P.O. Box 278 , Burlington , Ontario , Canada , L7R 3Y2

Sound Design Technologies assumes no liability for any errors or omissions in this document, or for the use of the circuits or devices described herein. The sale of the circuit or device described herein does not imply any patent license, and Sound Design Technologies makes no representation that the circuit or device is free from patent infringement.

Sound Design Technologies and Sound Design Technologies logo are registered trademarks of Sound Design Technologies, Ltd.

© Copyright 2007 Sound Design Technologies, Ltd. All rights reserved. Printed in Canada.

www.SoundDesignTechnologies.com